

CARACTÉRISTIQUES

- Cuve ronde ou cuve rectangulaire.
- Taloches en PVC.
- Cuve avec bague et couteaux en inox.
- Sur roulettes avec freins.

FEATURES

- Round bowl or rectangular bowl.
- Press-segments in PVC.
- Bowl with stainless-steel ring and blades.
- On castors with locking system.

EIGENSCHAPPEN

- Ronde kuip of rechthoekige kuip.
- Drukvoeten in PVC.
- Kuip met roestrijstalen ring en messen.
- Met zwenkwielen met rem.



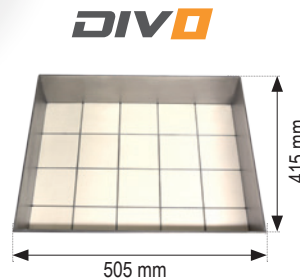
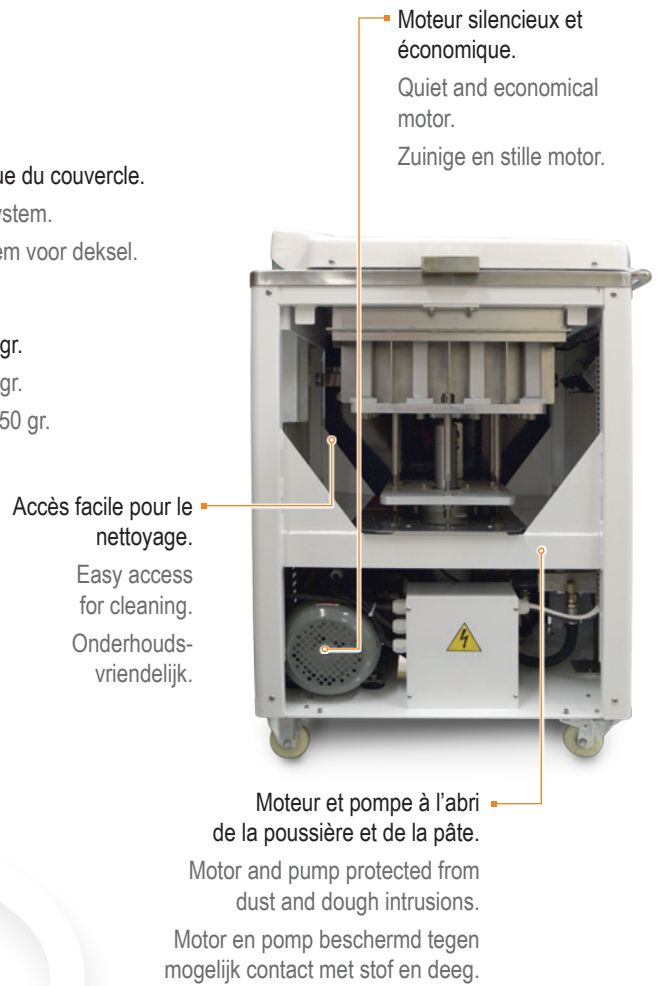

DIVOTRAD

Simplicité d'utilisation absolue.

Easy to use.

Uiterst gebruiksvriendelijk.

Regardez notre vidéo

Watch our video

Bekijk onze video



Pour des pâtes très hydratées.
For highly hydrated dough.
Voor hoog gehydrateerd deeg.

75%

Tapis en silicone.
Silicon mat.
Silicone mat.

Plaque de tassage en matière rigide.
Hard pressing plate.
Harde drukplaat.

Cadre en fonte d'aluminium avec grilles interchangeables
Cast aluminum frame with interchangeable grids.
Gegoten aluminium frame met verwisselbare roosters.

Production jusqu'à 2500 pièces/heure
Production up to 2500 pieces/hour
Productie tot 2500 stukken/uur



Système pour le réglage du temps de la pression.
Adjustable system for pressing time.
Druktijdregelaar.

DIVOTRAD

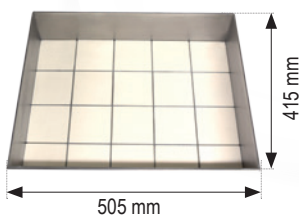

Option: Echelle inox | Inox trolley
 Optie: RVS rek

Bacs Bins Bakken	14
Couvercles Lids Dekfels	14
Capacité Capacity Capaciteit	9,8 L (5 - 6 kg)



Demandez notre catalogue grilles avec un large éventail de possibilités.

Ask for our catalogue of grids with a wide range of possibilities.

Vraag onze catalogus van de roosters, met tal van mogelijkheden.

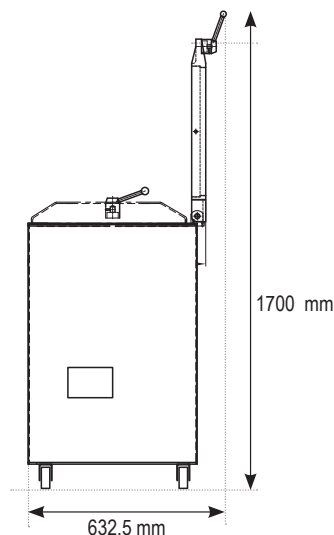
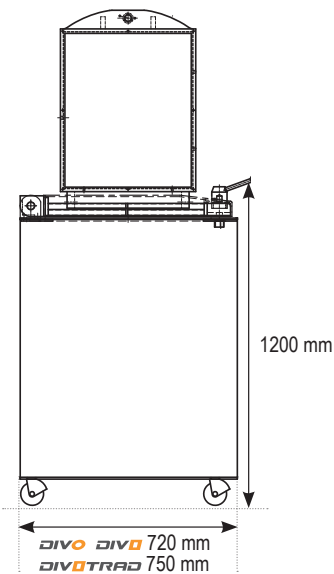

MODEL	DIVOTRAD	DIVO	DIVO
DIVISIONS DIVISIONS VERDELINGEN	20	20	20
CAPACITÉ par division CAPACITY per division CAPACITEIT per verdeling	Grid	100 - 950 g	100 - 950 g
PUISSANCE MOTEUR MOTOR POWER MOTORVERMOGEN	2,2 kW	2,2 kW	2,2 kW
POIDS NET MACHINE NET WEIGHT MACHINE NETTOGEWICHT MACHINE	285 kg	265 kg	265 kg
VOLTAGE VOLTAGE SPANNING	230/400V 3Ph 50Hz	230/400V 3Ph 50Hz	230/400V 3Ph 50Hz
OPTION ECHELLE OPTION TROLLEY OPTIE REK	✓	✓	✓
OPTION CHASSIS EN INOX OPTION BODY IN STAINLESS STEEL OPTIE BEHUIZING IN RVS	✓	✓	✓